



Dual-polarity LTE-Richtantenne

Best.Nr. 18705.12DUAL



Dual-polarity Richtantenne mit zwei Antennenanschlüssen für alle üblichen Router z.B. Huawei 9100 LTE.

2x 12 dBi Gewinn, für den unteren LTE-Frequenzbereich 790-860 MHz. Geeignet um schwache Signale zu verstärken und weit entfernte Basisstationen zu erreichen. Zur Aussenmontage am Mast oder Wandhalter, wetterfest. Lieferung erfolgt inklusive Schwenk/Neigehalterung zum präzisen Ausrichten der Antenne.

Electrical specifications	
Frequency range (MHz)	790-860
Polarization	$\pm 45^\circ$
Gain (dBi)	2x12
Electrical Downtilt ($^\circ$)	0
Half-power beam width ($^\circ$)	Horizontal:65° Vertical:30°
Front-to-back ratio (dB)	≥ 25
Cross-polar discrimination (dB)	$\geq 15(\pm 60^\circ \geq 10)$
Isolation (dB)	≥ 28
Impedance (Ω)	50
VSWR	≤ 1.5
Intermodulation IM3 (2x43dBm carrier)	$\leq -150\text{dBc}$
Maximum power (W)	500
Lighting protection	DC Ground

Mechanical specifications	
Connector	2xN Female
Connector position	Bottom
Height/width/depth (mm)	650x280x85
Packing size (mm)	720x340x190
Weight (kg)	5.5
Radome material	UPVC
Radome color	Gray
Mechanical tilt ($^\circ$)	0~10
Operating temperature	-40~60°
Rated wind velocity (m/s)	60
Suitable pole diameter (mm)	50~75
Part no.	18705.12DUAL

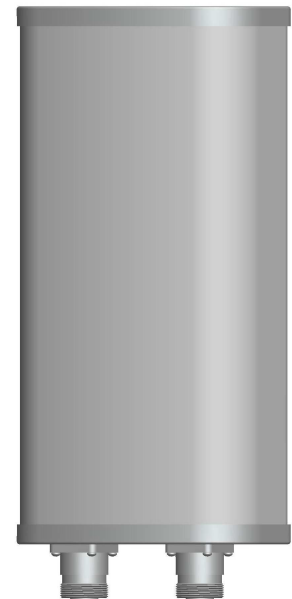

$\pm 45^\circ$ Polarization

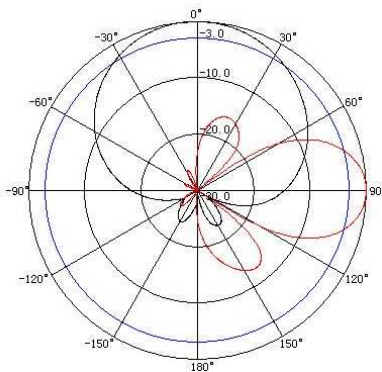

WiMo Antennen und Elektronik GmbH

Am Gäxwald 14, D-76863 Herxheim Tel. (07276) 96680 FAX 9668-11

<http://www.wimo.com>

e-mail: info@wimo.com



Dual-polarity LTE-Richtantenne

Best.Nr. 18705.12DUAL

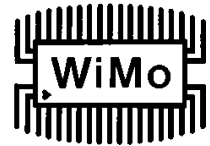

Installation Instructions

GENERAL

A. Read the instructions thoroughly before assembly. Follow the sequences for proper assembly and operation.

B. The installation maintenance or removal of an antenna requires qualified experienced personnel. The company's installation instructions have been written and illustrated for such installation personnel. Antenna systems should be inspected once a year by qualified personnel to verify proper installation, maintenance and condition of equipment. The company disclaims any liability or responsibility for the results of improper or unsafe installation or maintenance practices.

INSTALLATION TOOLS

2PCS 13mm open end wrench(for M8 hardware).

INSTALLATION SKETCH

Carefully remove all parts from shipping boxes. The contents should correspond with the drawing. Any damage or shortage will prevent satisfactory assembly installation and operation of the antenna. See below:

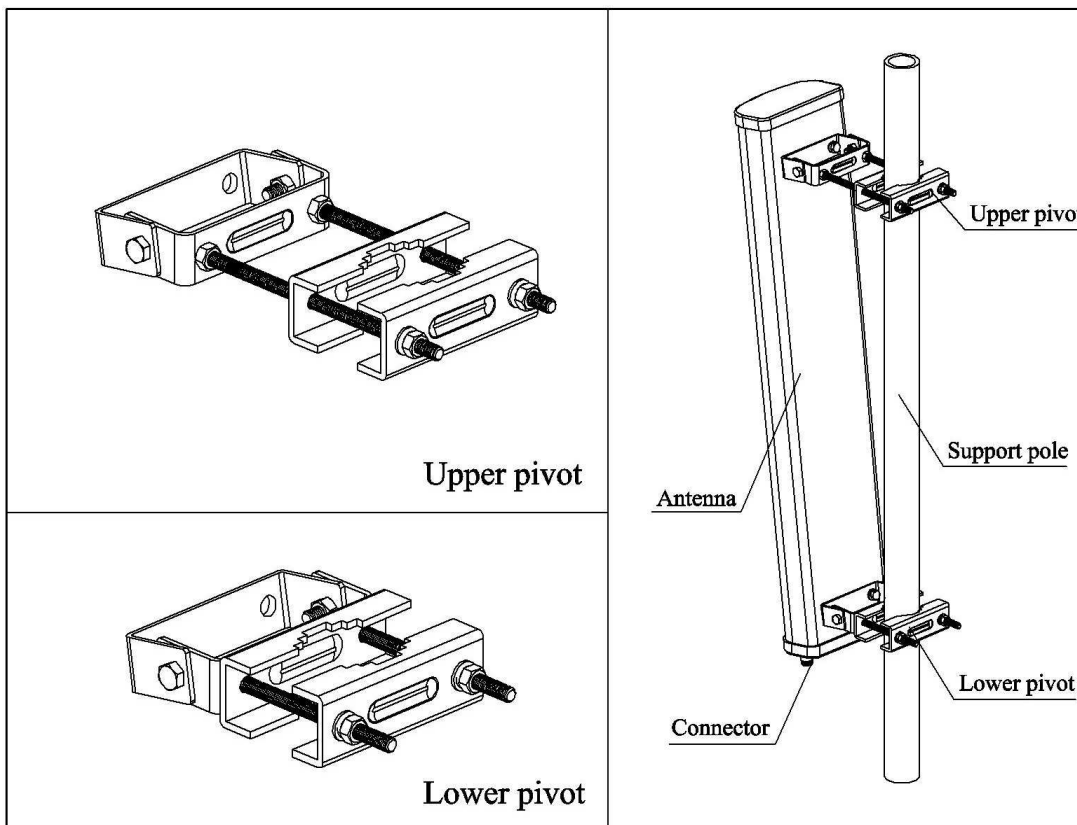

INSTALLATION PROCESS

1. Fix the mount kits and antenna onto the support pole($\phi 50-75$), then adjust the horizontal angle and the mechanical downtilt angle of antenna to suitable direction. Screw all nut of the mount kits.

2. Open the plug cover in the bottom of the antenna, and fix the cable attachment, screw nut tighten. Waped the juncture around with waterproof tape.

WiMo Antennen und Elektronik GmbH

Am Gäxwald 14, D-76863 Herxheim Tel. (07276) 96680 FAX 9668-11

<http://www.wimo.com>

e-mail: info@wimo.com