

Automatic-Matching 200-Memory Antenna Tuner FC-40 Installation Instructions

Thank you for your purchase of the model FC-40 Automatic-Matching 200-Memory Antenna Tuner. The FC-40 microprocessor controlled antenna impedance matching network is designed to provide wideband transmitting capability for many Yaesu transceivers*, when used with an end-fed random wire or long whip antenna.

The FC-40 makes use of the control circuitry built into the transceiver, which allows the operator to control and monitor automatic operation of the FC-40, which mounts near the antenna feedpoint. The FC-40 uses specially -selected, thermally-stable components, and is housed in a waterproof case to withstand severe environmental conditions with high reliability.

A carefully-chosen combination of solid-state switching components and high-speed relays allows the FC-40 to match a wide variety of antennas to within a 2:1 SWR on 1.6 - 54 MHz, typically in less than eight seconds. Transmitter power required for matching may be as little as 4 - 60 Watts, and matching settings are automatically stored in memory for instant recall when the same frequency range is selected later. The FC-40 is a current feed design and may not be able to match frequencies that are near 1/2 wavelength (or multiple) of the antenna element.



*: Check with your Yaesu dealer for a list of current transceivers that may be used with the FC-40 Antenna Tuner.

Specifications









Operating Frequency Range:	1.6 - 54 MHz with 20+ m end-fed wire 7 - 54 MHz with YA-007 HF 2.5 m Mobile Whip Antenna
Input Impedance:	50 Ohms
Maximum Input Power:	100 W (3 minutes maximum continuous TX)
Matched SWR:	2.0:1 or less (if antenna is not near a multiple of $\lambda/2$)
Tune-up Power:	4 - 60 W
Tune-up Time:	8 seconds maximum
Impedance Matching Memories:	200 channels
Operating Temperature:	+14 °F to +122 °F (-10 °C to +50 °C)
Power supply:	13.8V DC±15% (supplied from transceiver)
Case Size (WHD):	9" x 7" x 2.1" (228 x 175 x 55 mm)
Weight:	2.6 lbs. (1.2kg)

Specifications subject to change without notice of obligation.

Symbols placed on the equipment

-  Dangerous voltage
-  Protective earth, protective ground

Supplied Accessories

Control Cable 5m	1	Machine Screws, Nuts & Washers (set)	
Coaxial Cable (5D-2V) 5m	1	• Screws (5 x 20) 	4
Sealing Tape 50cm	1	• Screws (M5 x 20) 	4
Ferrite Core	1	• Outer washer (OW5) 	4
U-bolt Kit		• Washers (FW5) 	8
• U-bolts	2	• Nuts (N5) 	4
• Plate	2		
• Washers (FW6) 	4		
• Spring washers (SW6) 	4		
• Nuts (N6) 	4		

Mounting the FC-40

The mounting method for the FC-40 is determined by the antenna type and station location. In all installations, however, the FC-40 must be located at the intended feedpoint for the antenna. The drawings below show examples of placement of the FC-40 in typical mounting locations. Following are several important considerations to bear in mind during installation:

- The side of the FC-40 with the cables extruding is oriented downward (to minimize the chance of water leakage through the cable holes).
- The grounding wire (for monopoles) and part(s) of the antenna wire between the tuner terminals and the nearest antenna support should be as short as possible.
- The antenna must not touch anything except supporting insulators.
- If there is any chance of stress on the cables to the transceiver, they should be supported independently, with a slack loop between their support and the FC-40.

For base stations, the FC-40 may be mounted either on a flat surface such as the wooden board shown in Figure 1, or a 2.16" - 2.55" (55-65 mm) mast, using the supplied U-bolt kit shown in Figure 2.

For mobile installations, the FC-40 should be bolted to a flat surface using either bolts or self-tapping screws (Figure 3) inside the trunk or cabin, as close to the base of the antenna as possible. Note that it can be mounted horizontally if well protected from the weather.

After mounting the FC-40, connect the cables from the FC-40 to the ANT and TUNER (or CAT/LINEAR) jacks (depends on the transceiver) on the rear panel of the transceiver. Refer to the transceiver's Operating Manual for details of the interconnections with the transceiver. If you use the FC-40 with the Yaesu FT-857D/-897D transceiver, refer to the instructions on the opposite page of this manual for interconnection details.

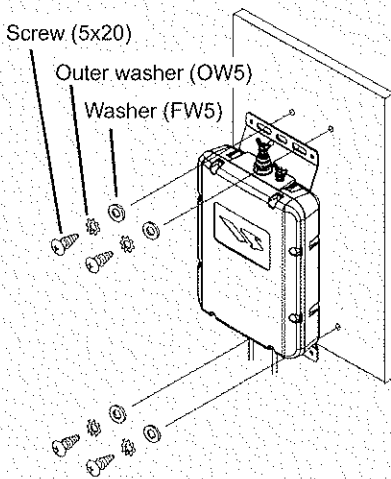

Figure 1

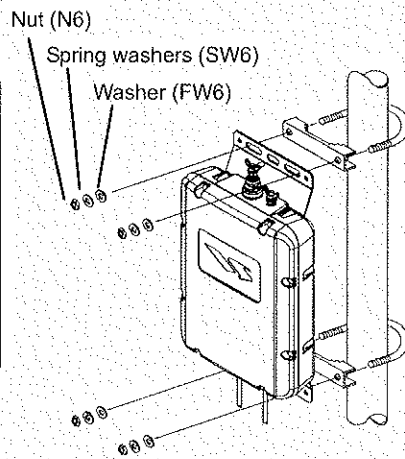

Figure 2

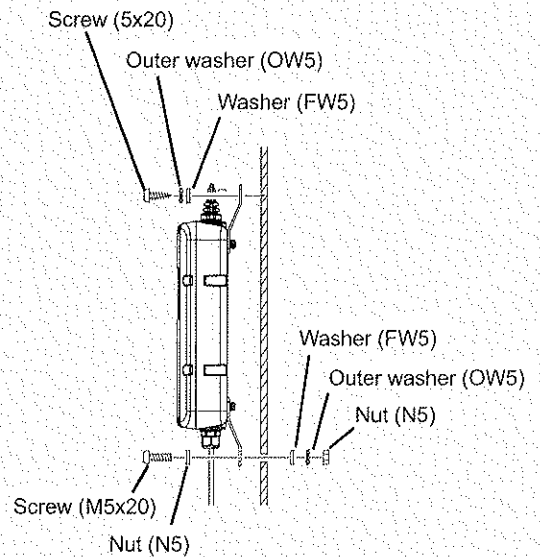
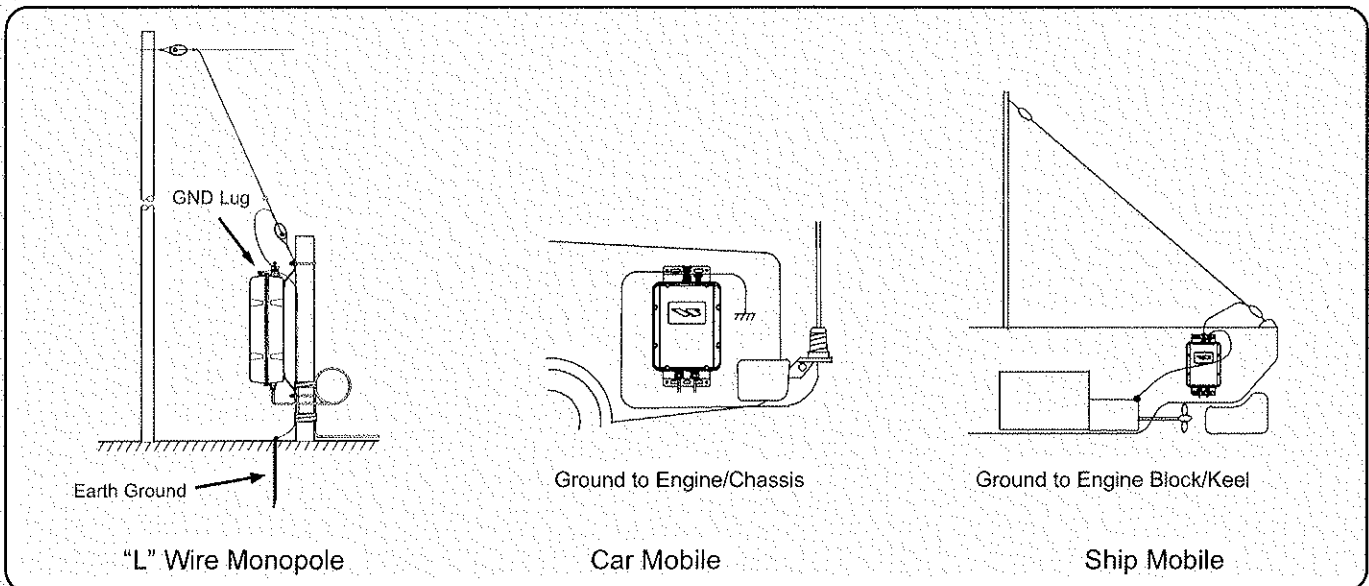

Figure 3



"L" Wire Monopole

Car Mobile

Ship Mobile

Tuner Operation

Please see your transceiver's Operating Manual for operation with the FC-40 Tuner.

See the instructions at the right side of this page for operation of the FC-40 with FT-857D/-897D transceivers.

Cautions

- Only connect cables to the FC-40 after switching the transceiver off.
- If the FC-40 doesn't tune even though you have pushed the TUNER switch of the transceiver, it may be because the antenna or its coaxial cable has a serious problem (very high or low impedance due to "open" or "short") or (the antenna element is near 1/2 wavelength or multiple of the desired frequency). Please check the antenna and coax if this happens.
- Take appropriate measures to ensure that there is no possibility that someone may come in contact with the antenna or FC-40 ANT terminal while your station is transmitting. Observe all practical and regulatory requirements for protecting yourself and the public from the effects of radio frequency radiation from your antenna system.

Grounding

The FC-40 antenna tuner, requires an effective ground system for maximum electrical safety and best communications effectiveness. A good ground system can contribute to station efficiency in a number of ways:

- It can minimize the possibility of electrical shock to the operator.
- It can minimize the possibility of erratic transceiver/accessory operation caused by RF feedback and/or improper current flow through logic devices.

⚠ To prevent damage from lightning, atmospheric electricity, electrical shock etc., please provide a good earth ground.

Use a short, thick (more than 1.25 sq) cable (color: yellow/green) to connect your FC-40 to the buried ground rod (or alternative earth ground system).

Please follow the outline in the illustration regarding the proper connection of earth ground.

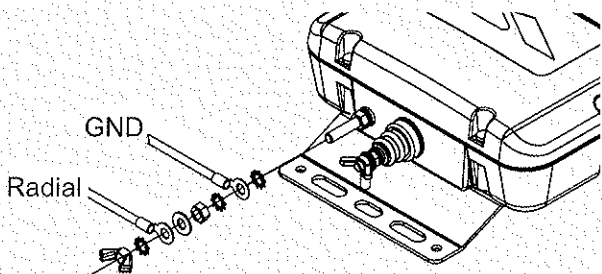

PROPER GROUND CONNECTION

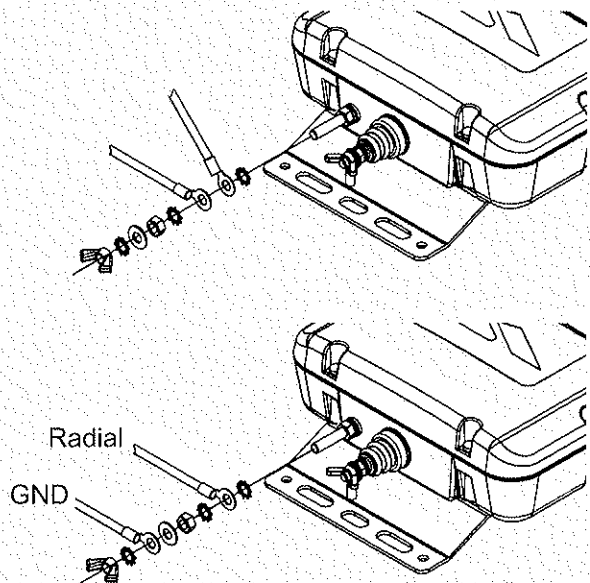

IMPROPER GROUND CONNECTION

- Inspect the ground system - inside the station as well as outside - on a regular basis to ensure continued performance and safety.
- Besides following the above guidelines carefully, note that household or industrial gas lines must never be used in an attempt to establish an electrical ground.
- Protective ground terminal is made of stainless steel. In order to prevent corrosion, please avoid contact with zinc, magnesium, and aluminum.

Interconnections to FT-897D and FT-857D

After mounting, connect the cables from the FC-40 to the ANT and TUNER jacks on the rear panel of the FT-897D/FT-857D Transceiver.

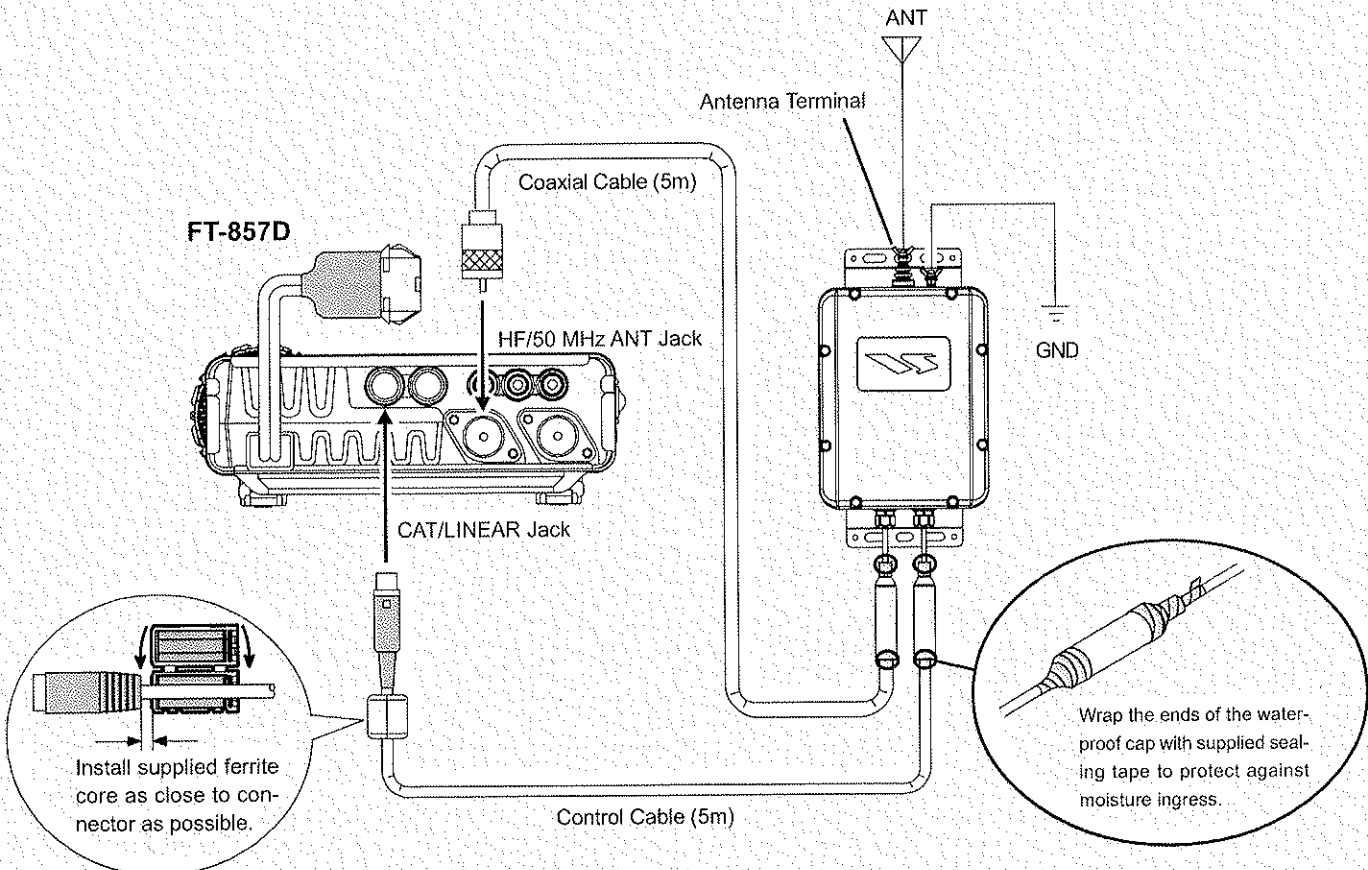
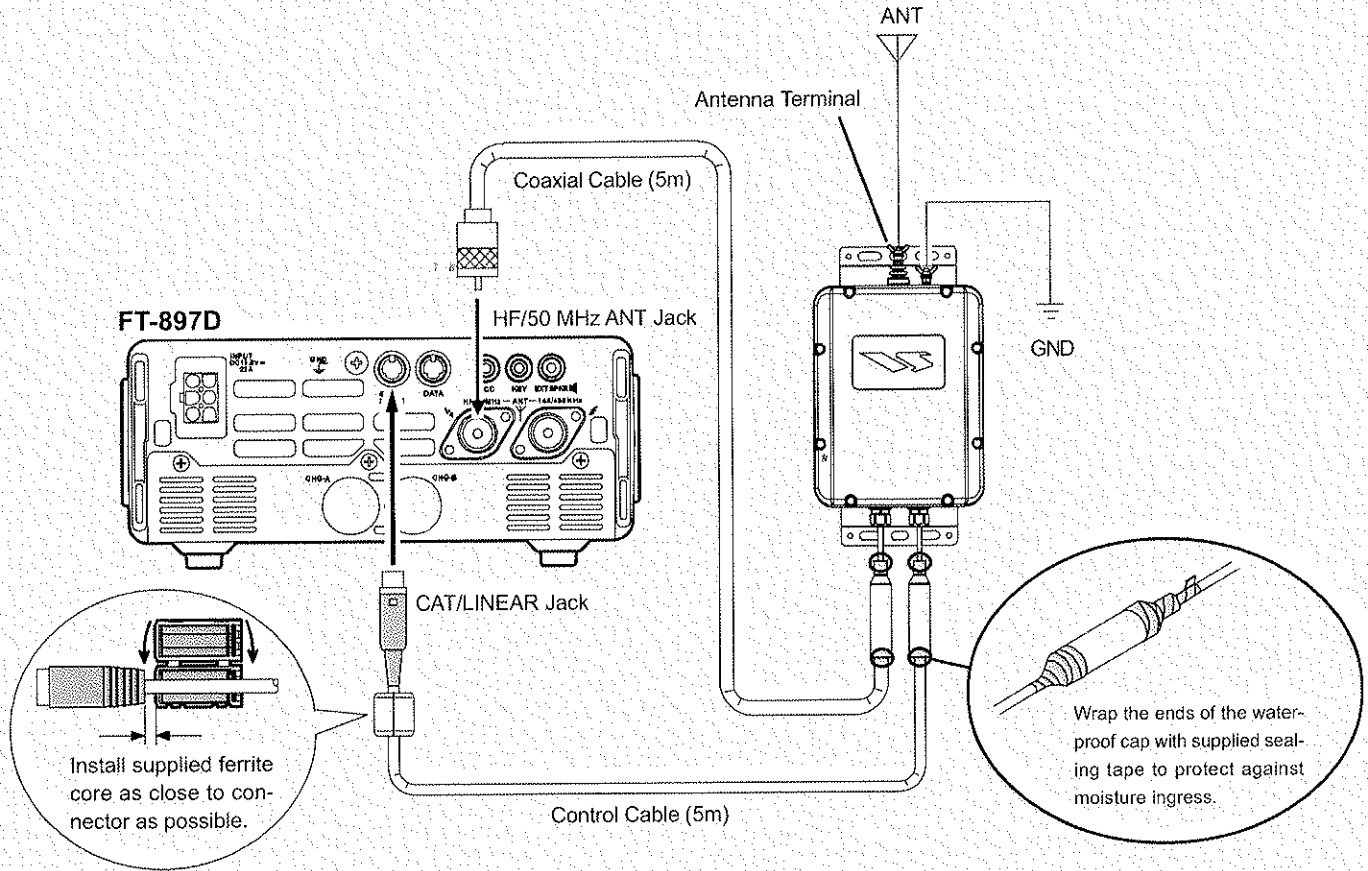

FT-857D/-897D Tuner Operation

1. Press and hold in the **[F]** (**FUNC**) key for one second to activate the Menu mode.
2. Rotate the **MEM/WFO CH** (FT-857D: **SELECT**) knob to recall Menu Mode No-001 [EXT MENU], then rotate the **DIAL** to change the setting to "ON" to enable the extended Menu Mode.
3. Rotate the **MEM/WFO CH** (FT-857D: **SELECT**) knob to recall Menu Mode No-020 [CAT/LIN/TUN]. The default setting for this Menu is "CAT." Rotate the **DIAL** to change the setting to "TUNER."
4. Press and hold in the **[F]** (**FUNC**) key for one second to save the new setting and exit, then turn the transceiver off.
5. Set up the FC-40 and FT-897D/-857D per the illustration on the opposite page of this manual, then turn on the transceiver's power again. **Do not set up the FC-40 and FT-897D/-857D before changing the Menu Mode, item No-020 [CAT/LIN/TUN].**
6. Press and hold in the **[F]** (**FUNC**) key for one second to activate the Menu mode.
7. Rotate the **MEM/WFO CH** (FT-857D: **SELECT**) knob to recall Menu Mode No-085 [TUNER/ATAS]. The default setting for this Menu is "OFF." Rotate the **DIAL** to change the setting to "TUNER."
8. Press and hold in the **[F]** (**FUNC**) key for one second to save the new setting and exit.
9. Press the **[F]** (**FUNC**) key, as needed, to recall Multi Function Row "k" [TUNE, DOWN, UP].
10. Press the **[A]**(TUNE) key to turn the FC-40 on. "Parentheses" will appear on both sides of the "TUNE" indication, and "TUNR" will appear on the LCD.

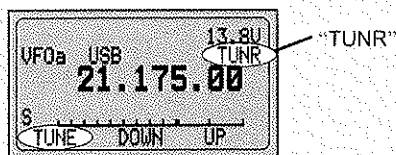

FT-897D



FT-857D

11. Press and hold in the **[A]**(TUNE) key to initiate automatic tuning. The FT-897D/-857D transmitter will be activated, a carrier signal will be sent out, and the coils and capacitors in the FC-40 will be selected/adjusted for optimum SWR. When tuning is complete, the transmission will cease, and you will be ready for operation on this frequency.

Tuning data will be stored in the FC-40's Memory system. See the discussion below for details on how this works. If using the FC-40 with the FT-897D under internal battery (FNB-78) power, the FC-40 may not operate properly if the battery voltage is low.

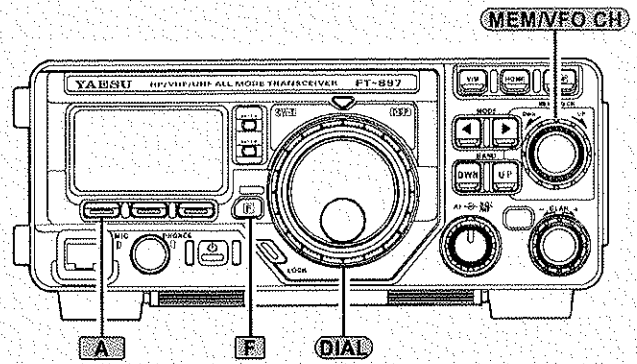

FT-897D

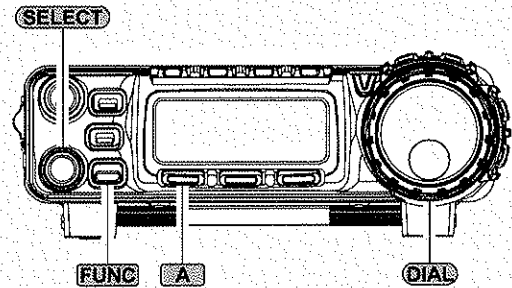

FT-857D

IMPORTANT!

The FC-40, working in concert with the FT-897D/-857D, can store impedance matching data in its micro-computer memory, so as to provide instant adjustment as you transmit in different areas of a particular band. A total of 200 memories are provided, with the capability to resolve new tuning data every 10 kHz. A few guidelines should be noted regarding the FC-40's memory system:

Tuning data is stored when you make an active effort to store it by pressing and holding in the **[A]**(TUNE) key for one second. Although the tuner will automatically activate itself if it encounters more than 2:1 SWR, this memory will not be stored unless you have pressed the **[A]**(TUNE) key for one second. This allows you to store your favorite operating frequency areas into tuner memory without tying up memory space with matching data on seldom-used frequencies.

If the FC-40 cannot resolve a satisfactory match because the SWR is above 2:1, the tuning process will stop, and no memory data will be stored. However, you may wish to move frequency a few kHz, then press the **[A]**(TUNE) key again for one second, as slight changes in the reactance may allow a match to be obtained. Then go back to the original frequency and try again.

If the impedance encountered by the FC-40 exceeds 2:1, and the "HSWR" icon is illuminated, the microprocessor will not retain the tuning data for that frequency, as the FC-40 presumes that you will want to adjust or repair your antenna system so as to correct the high SWR condition.

FC-40 Circuit Diagram

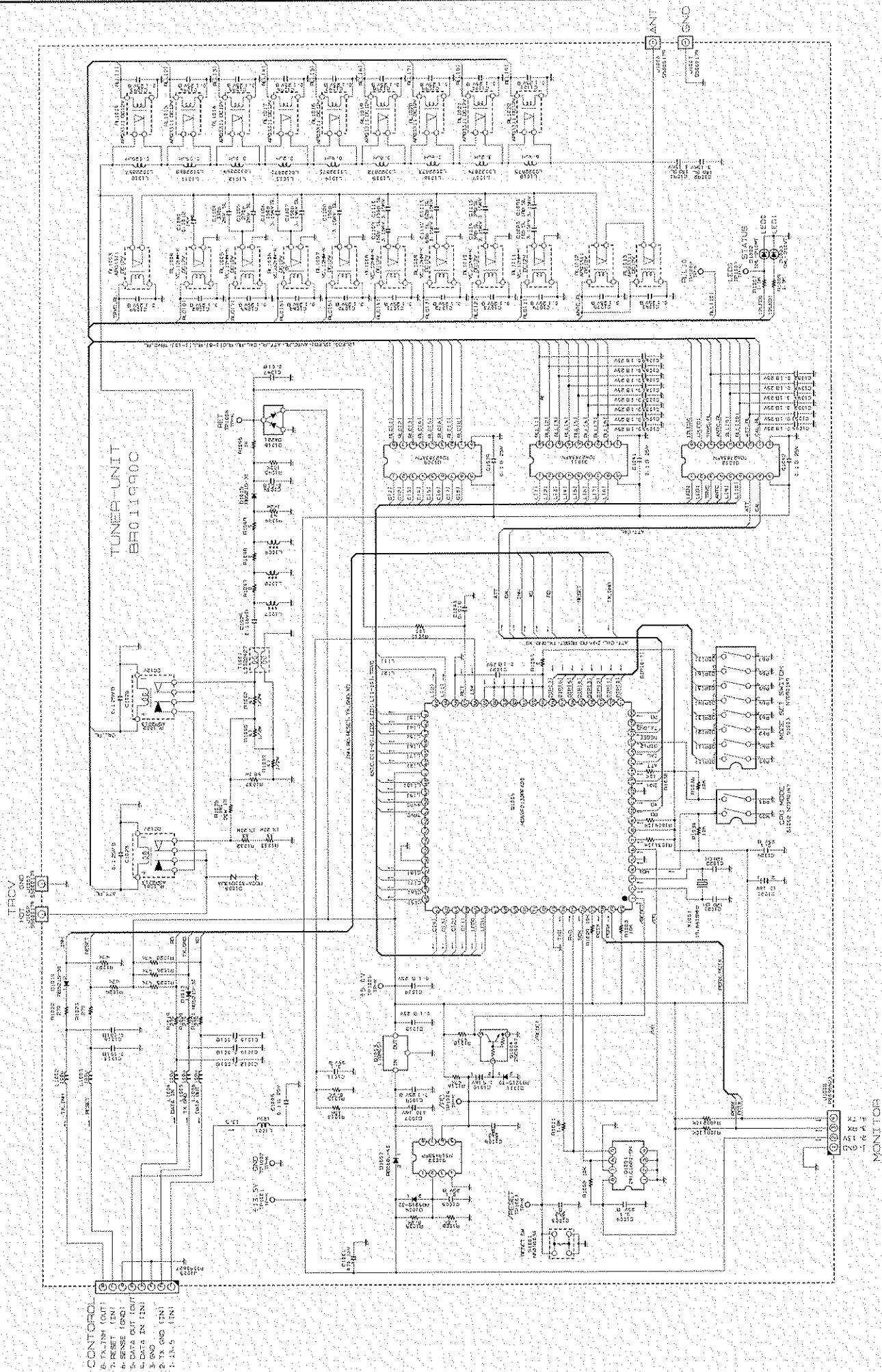

- CONTROL**
- 6. TX/INH (OUT)
 - 7. RESET (IN)
 - 4. SENSE (END)
 - 5. DATA OUT (OUT)
 - 4. DATA IN (IN)
 - 3. GND
 - 2. TX GND (IN)
 - 1. TX/S (IN)

- MONITOR**
- 7. 1
 - 6. 2
 - 5. 3
 - 4. 4
 - 3. 5
 - 2. 6
 - 1. 7

Disposal of Electrical and Electronic Equipment

Products with the symbol (crossed-out wheeled bin) cannot be disposed of as household waste. Electronic and Electrical Equipment should be recycled at a facility capable of handling these items and their waste by products. Please contact a local equipment supplier representative or service center for information about the waste collection system in your country.



YAESU

The radio

YAESU MUSEN CO., LTD.

Tennozu Parkside Building
2-5-8 Higashi-Shinagawa, Shinagawa-ku, Tokyo 140-0002 Japan

YAESU USA

6125 Phyllis Drive, Cypress, CA 90630, U.S.A.

YAESU UK

Unit 12, Sun Valley Business Park, Winnall Close
Winchester, Hampshire, SO23 0LB, U.K.

1705Y-DS

Printed in Japan



E A D 7 7 X 1 0 E