

# QO-100 DX Patrol Ground Station

An all-in-a-box station for easy QO-100 operation

**DX PATROL**

August 12, 2021

Authored by: CT1FFU v2.0

## QO-100 DX Patrol Ground Station

An all-in-a-box station for easy QO-100 operation



An all-in-a-box station for easy QO-100 operation

## Table of content

MAIN CHARACTERISTICS.....	3
SIMPLIFIED BLOCK DIAGRAM.....	4
GENERAL OVERVIEW.....	5
CONNECTING THE GROUND STATION.....	6
EQUIPMENT NEEDED.....	6
HOW TO CONNECT?.....	6
OPERATING THE GROUND STATION.....	7
SWITCH THE GROUND STATION ON WITH THE SWITCH ON THE FRONTPANEL.....	7
SCROLLING THE MENU.....	7
WELCOME SCREEN.....	7
SATELLITE INPUT POWER.....	8
INFORMATION MENU.....	8
GPS MENU.....	9
GROUND STATION INFORMATION.....	9
READY FOR OPERATION.....	10
TRANSMITTING.....	10
CURRENT BANDPLAN.....	11
ADJUSTMENTS.....	12
IF LEVELS.....	12
POWER METER LEVEL.....	13
DETAILED VIEWS AND SCHEMATIC.....	14
INSIDE VIEWS.....	14
PTT/VOX CIRCUIT.....	16
INCLUDED PARTS LIST.....	17
MODIFIED DX PATROL LNB.....	17
DX PATROL GPS + GLONASS ANTENNA.....	17
AVAILABLE ACCESSORIES.....	18
DX PATROL HELIX QO-100 ANTENNA.....	18
DXPATROL STANDALONE RX SET.....	19
COAX CABLE CONSIDERATIONS.....	20
CONTACT INFORMATION.....	20

## Main Characteristics.

The Ground Station works as a simplex radio station (RX/TX on 70cm)

It's up to the operator, to arrange continuous monitoring of his signal via WEBSDR or other means like separate RX convertor \*, as recommended by AMSAT.

- Reception frequency: 10489.500 to 10490.000MHz;
- Transmission Frequency: 2400.000 to 2400.500 MHz;
- IF Frequency: 432.500 to 433.000 MHz;
  
- GPS Lock internal 10MHz reference;
- Transverter stage output up to 200mW;
- Maximum Output RF Power 10 W @2.4 GHz based on NXP MHR1008NT1;
  
- Factory set input power 250 mW for VOX operation \* @432.5 MHz (*\*can be adjusted with R38*);
- Maximum input RF 5W (500mW optimum drive);
- Auto TX and RX by VOX PTT
  
- Supply voltage 12V to 14V;
- Thermal protection > 60° C;
- SWR protection > 1:3;
- High voltage input protection;
- Satellite Strength signal indication;
- Power output bar and Watt indication;
- SWR bar and ratio indication;
- Internal 3A fuse protection;
  
- NMEA GPS indication;
- Number of GPS satellites in range;
- GPS coordinates;
- QTH Locator presentation on screen;
- UTC clock and date;
  
- Mixer, Double Balanced Mixer ADE-35+

## Simplified block Diagram

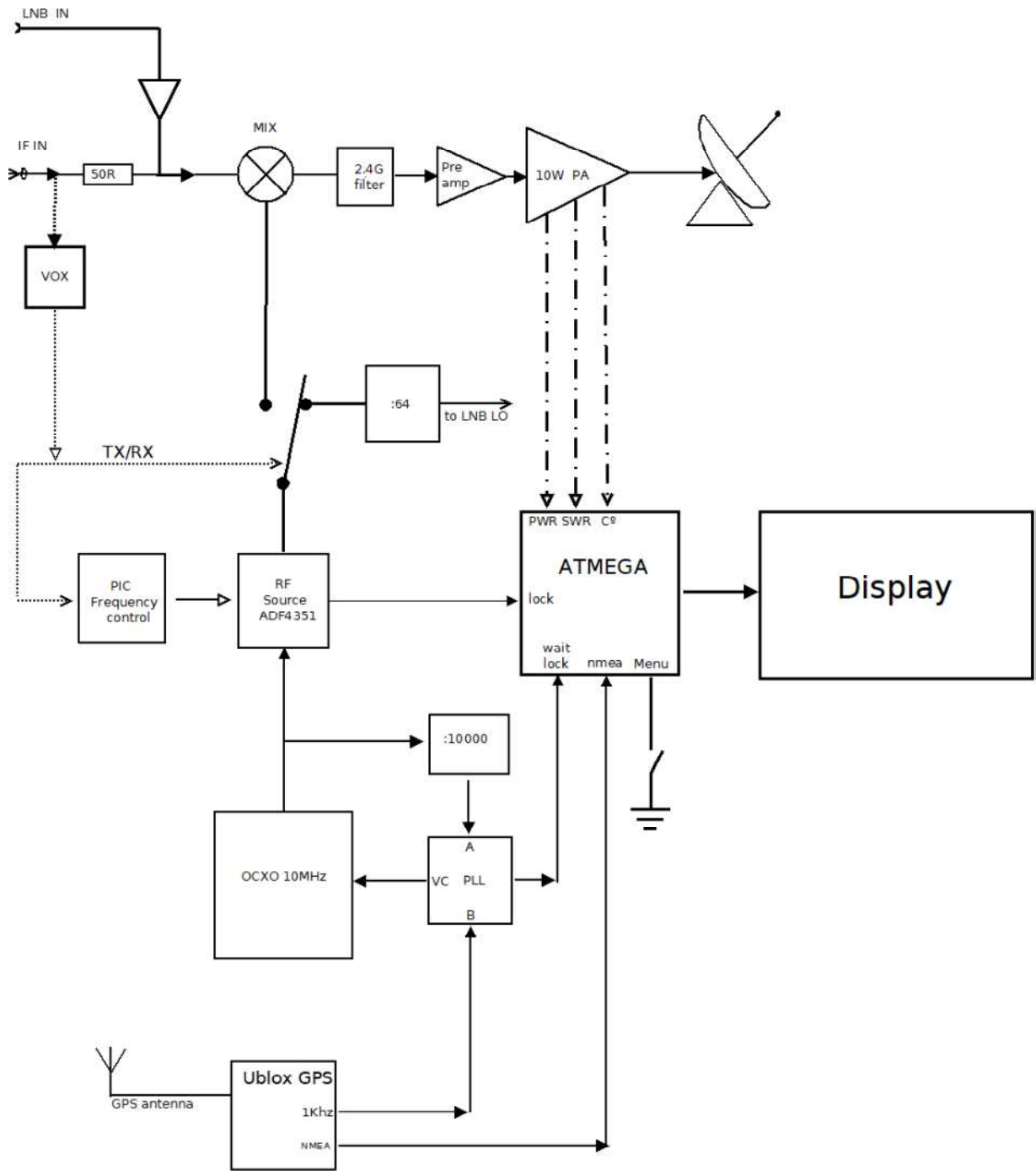

## General overview

### Front view



The Ground Station has 2 tilt feet on the bottom, front side, for easy access and use.

Left the menu button, next OLED screen and on the right the ON/OFF switch.

### Rear view

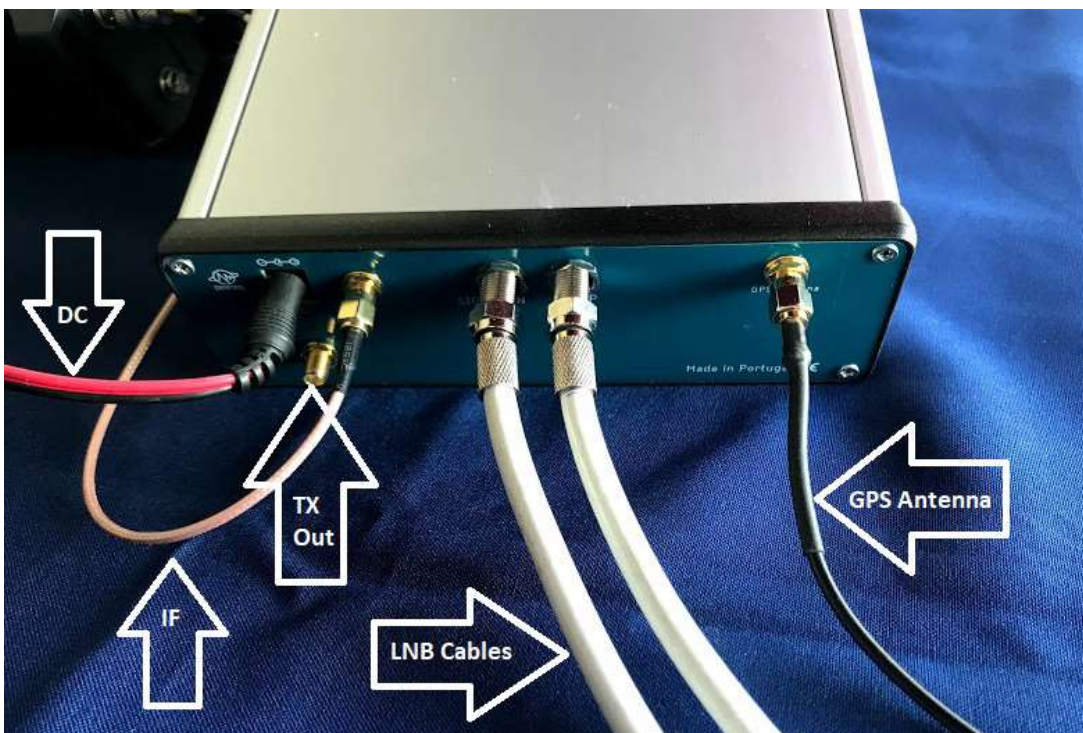

## Connecting the Ground Station

### Equipment needed.

- A power supply 12V or ( 13,8V) 5A minimum;
- Two coaxial TV 75 Ohm cables for satellite LNB fitted with male F connectors;
- Low loss coax cable (50ohm) from RF out to patch/helix antenna.

### How to connect?



WARNING

**Never** make these connections with Ground Station **ON**.

There is 12V Phantom Power on the cable and a short-circuit will happen if life wire touches the shield, damaging the Ground Station

1. Connect the Ground Station correctly to the LNB with 75 ohm cable with F connectors;

Cable 1: LO UP to LNB's input LO

Cable 2: SIG IN to LNB's SIG

2. Connect the GPS antenna to GPS input ( SMA connector);

GPS antenna must be outside with clear visibility to sky. The antenna is waterproof, but will be good to fit it inside a plastic bag to avoid rain damage. In some cases it can work on a window, even inside.

3. Connect IF to your UHF SSB with a 50 ohm coaxial cable fitted with a male SMA connector;
4. Connect the OUT RF to the transmitting antenna with a 50 ohm low loss coaxial cable
5. Connect the 12V power supply (center pin is positive pin)

## Operating the Ground Station

### Switch the Ground Station on with the switch on the frontpanel.

When turning ON you will see for some seconds the Splash Screen Logo of *DX patrol* and then the display will present a page as show in the picture below.



*RX mode*, no Power/SWR detected, Clock and Wait.

The clock is UTC time and it takes a few seconds to be visible. ( only visible with GPS satellites in range).

While the OCXO (oven-controlled crystal oscillator) is warming up, the WAIT indication is flashing. This can take a few minutes.

### Scrolling the menu

Pressing the Menu Button advances You in the menu, press and hold the button will freeze the chosen menu page.

#### Welcome screen





## Satellite input power



This page shows input satellite strength. This is shown in dBm and it's very useful to point the dish and fine adjustment of LNB in the focal point.

## Information menu



This page shows:

- the input DC voltage;
- PA temperature;
- Internal LO source ADF4351 lock status;
- GPS lock status (this can take a few minutes).

## GPS menu



Overview of the GPS data.

- Geographic Coordinates;
- Date and UTC time;
- Number of GPS in range;
- WW QTH locator.

## Ground Station information

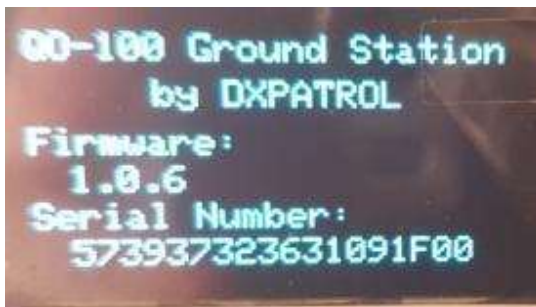

- Current FW version (August 2021)
- Serial number.

## Ready for operation

When both LOCK indications are shown on screen, you are ready to start using the QO-100 satellite.

### IMPORTANT

**Do not start transmission till both references are locked.**

**In the warm up phase, that is till dual lock, frequency excursions as big as 25 kHz are possible!**

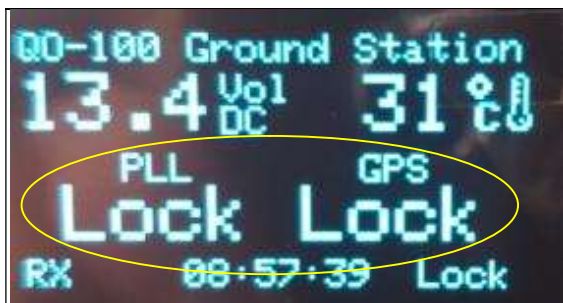

Any UHF SSB radio as IF will receive very loud and clear satellite signals. Lower beacon should be at 432.500 MHz and upper beacon should be at 433.000 MHz.

The Ground Station will receive the QO-100 very clearly with the included LNB with any dish, even small ones as 30 cm. However, in transmission, to have a clear loud signal, you should use a minimum 60cm dish and an efficient antenna feed, such as a Helix or a Patch antenna, low loss cable as short as possible is preferred to feed the 2.4 GHz up to the dish.

*! Practical test have shown that with 4 Watts at the feed of a 1m offset dish you are very close to the CW beacon signal!*

## Transmitting

There is no need for any PTT, switch or cable (except for the coaxial cable from radio to Ground Station) to activate the Ground Station into TX mode.

Even 250mW of RF is enough to trigger the VOX and switch to TX mode.

The TX indication will be visible, as well the Output Power in Watts and in a bar-graph.

Maximum power is 10 W output and SWR bar and ratio will be presented if reflected power is detected. Alarm will display if SWR raises more than 1:3, to clear an SWR or Temperature Alarm, press Menu button.



## Current band plan

NB transponder Bandplan				
IF	UP	Mode	Down	
432,500	2400,000	CW beacon	10489,500	
432,505	2400,005	CW only		10489,505
432,540	2400,040	NB digital modes		10489,540
432,580	2400,080	Digital modes		10489,580
432,650	2400,150	SSB only		10489,650
432,745	2400,245	PSK beacon	10489,745	
432,255	2400,255	SSB only		10489,755
432,850	2400,350	Emergency frequency		10489,850
432,860	2400,360	Mixed mode & special purpose		10489,860
432,995	2400,495	CW beacon		10489,995
433,000	2400,500	CW beacon		10490,000

## Adjustments

### IF Levels

The set input level (factory setting) is **250mW**.

For maximum versatility the required input power of the Ground Station can be adjusted on the inside. The RX gain can be adjusted as well.

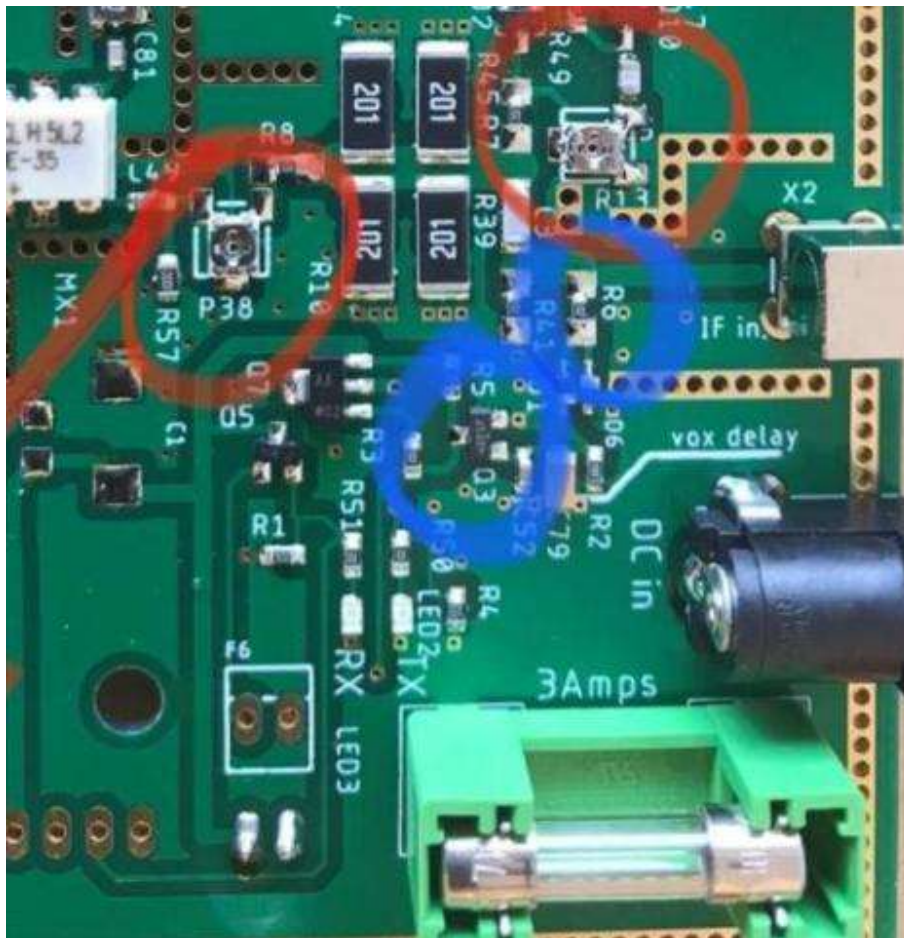

**P38** sets the TX gain level.

**R13** sets the RX gain level.

*The RX level should be set so that the IF receiver shows just a slight movement of the S-meter, typically S 1.*

## Power meter level

These are factory set and should not be adjusted without the proper external power meter equipment.

**R59** sets the forward power level indicated on the OLED display.

**R61** sets the SWR level indicated on the OLED display.



## Detailed views and schematic

### Inside views

Power amplifier on the bottom of the case

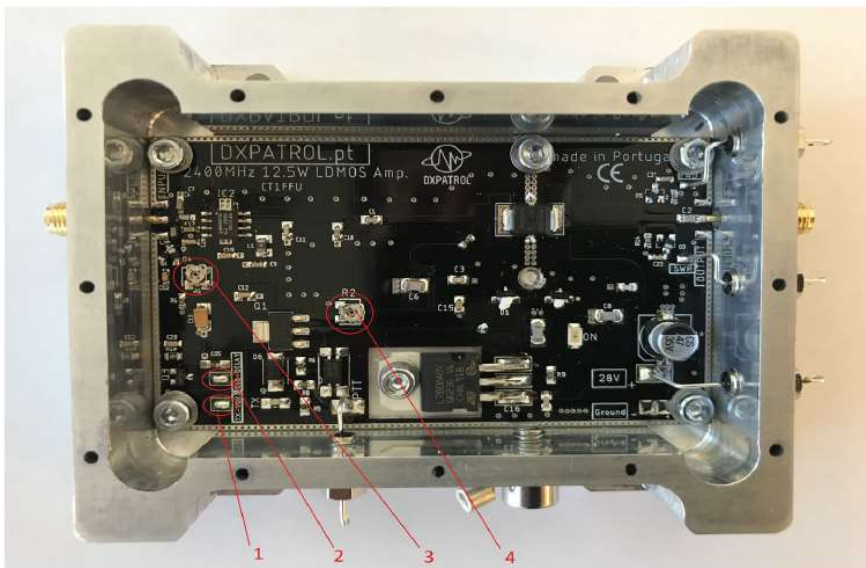

- 1- VOX PTT option. ( unsolder join to OFF)
- 2- VOX Delay option ( unsolder join to OFF)
- 3- IC1 BIAS current set. ( do NOT touch unless you know what you doing)
- 4- Ldmos Bias current set. ( do NOT touch unless you know what you doing)

On the left the 12v->28volts convertor, on the right the top board holding the RF parts

GPS module



Transverter output to final power amplifier



## PTT/VOX circuit

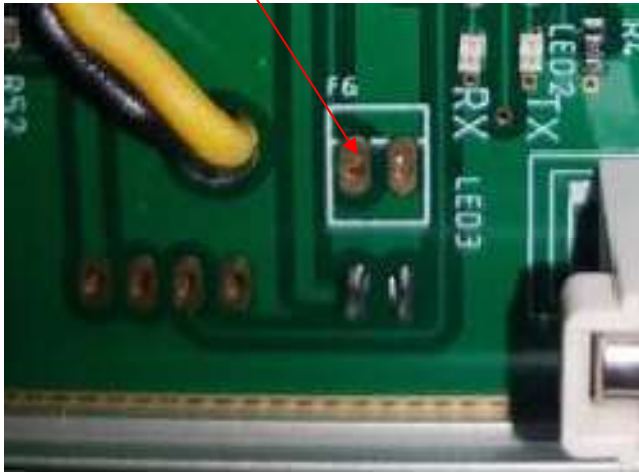
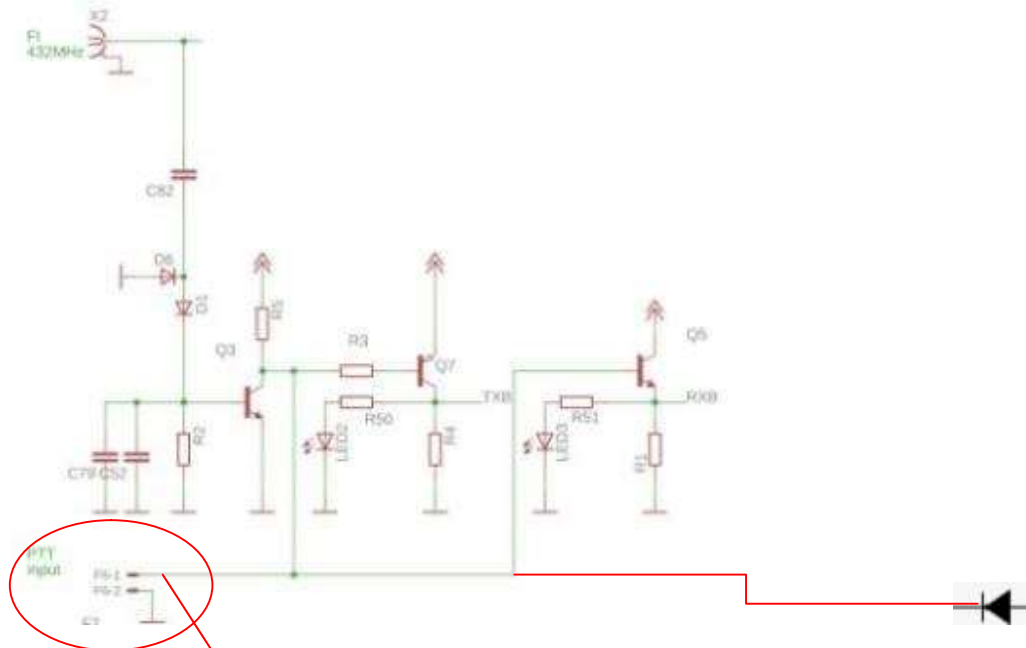

The F6 on the PCB board can be used for external PTT switching from the radio (requires soldering on the PCB) and adding a PTT connection, like a simple RCA jack, on the back of the QO-100 Ground station.

The F6 connection can be used to bypass the PA PTT as well, this is useful if you use very drive levels to the QO-100 Ground Station. A diode (e.g. 1N4001) from the PA PTT to F6-1 should be inserted in line (K to F6-1)

## Included parts list

### Modified DX Patrol LNB

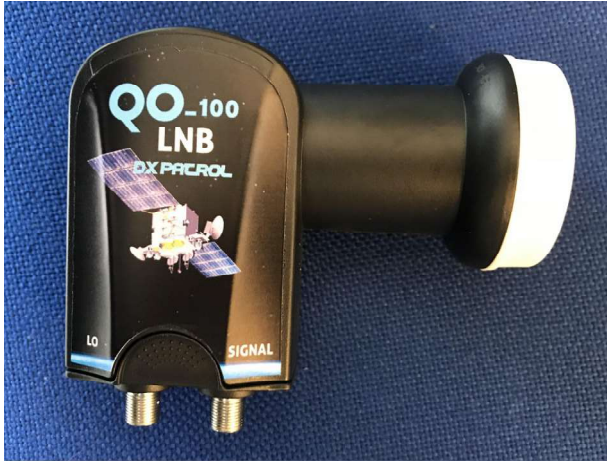

### DX Patrol GPS + Glonass antenna



## Available accessories

### DX PATROL Helix QO-100 antenna

With quick mount system

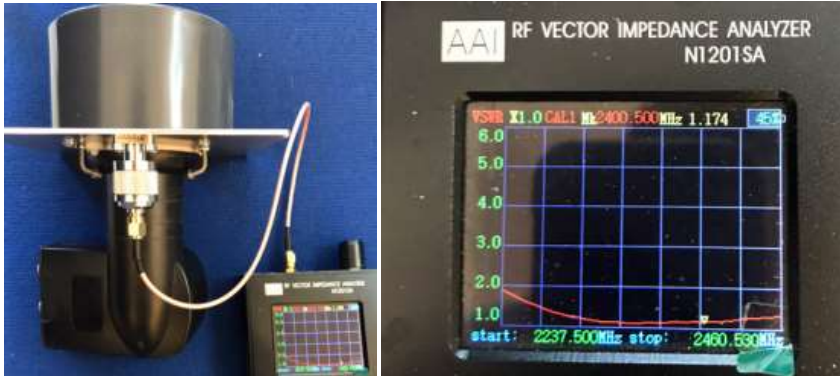

## DXPATROL standalone RX set



## Coax cable considerations

Make no mistake, coaxial cable loss at 2.4 GHz can be high, so it's important to use good quality coaxial cable from the feed to the Ground Station. Following table gives You an idea about the expected losses @2.4GHz just for 1 meter of coaxial cable!

	Diameter (mm)	Loss @2,4Ghz (dB) for 1m
RG188	2,60	1,37
RG316	2,45	1,37
Sucoform_86_FEP	2,50	1,05
Enviroflex 142	5,00	0,93
RG400 (M)	4,95	0,77
RG223/U	5,40	0,76
Sucoform 141 FEP	3,58	0,60
Aircell 5	5,00	0,48
Airborne 5	5,00	0,47
Hyperflex 5	5,40	0,43
Aircell 7	7,30	0,34
Ecoflex 10	10,20	0,23
Ultraflex 10	10,30	0,23
Airborne 10	10,30	0,20
Ecoflex 15	14,60	0,17
Ultraflex 13	12,70	0,17

A minimum of 1 meter coax for a 60cm off dish and 1.3m for a 1m offset dish is needed if one mounts the Dxpatrol Ground station just behind the dish.

One more thing to consider is the connector, a male SMA connector is readily available till Ecoflex 10 , Airborne10, Ultraflex 10 and alike. For the large cables adapters will be needed.

## Contact information

Website [www.dxpatrol.pt](http://www.dxpatrol.pt)

Email: [ct1ffu@gmail.com](mailto:ct1ffu@gmail.com) or [sales@dxpatrol.pt](mailto:sales@dxpatrol.pt)

Tel +351965626669